



(12) **EUROPEAN PATENT APPLICATION**

(43) Date of publication: **24.04.2002 Bulletin 2002/17**

(51) Int Cl.7: **G07F 7/10, G07F 19/00**

(21) Application number: **01308635.0**

(22) Date of filing: **10.10.2001**

(84) Designated Contracting States:  
**AT BE CH CY DE DK ES FI FR GB GR IE IT LI LU MC NL PT SE TR**  
 Designated Extension States:  
**AL LT LV MK RO SI**

(72) Inventor: **Terranova, Steven N.**  
**Cary, North Carolina 27511 (US)**

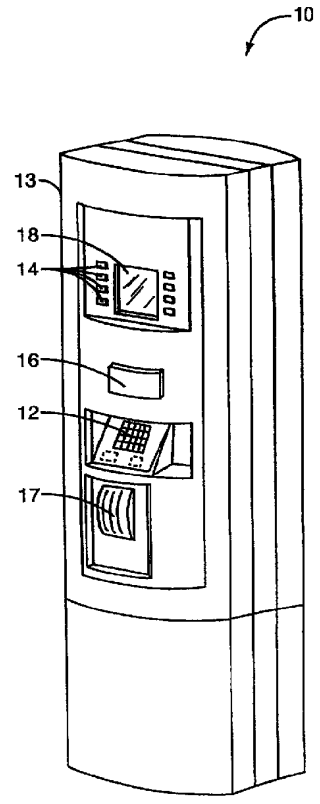
(74) Representative: **Fitchett, Stuart Paul et al**  
**Saunders & Dolleymore**  
**European Patent Attorneys**  
**9 Rickmansworth Road**  
**Watford WD18 0JU (GB)**

(30) Priority: **10.10.2000 US 685276**

(71) Applicant: **Marconi Commerce Systems Inc.**  
**Greensboro, NC 27420-2087 (US)**

(54) **A method of, and retail transaction station for, associating a customer transaction account with a customer identifier**

(57) A retail transactions station (10) identifies a customer by a customer identifier associated with the customer, possibly by interrogation a radio frequency identity (RFID) tag (20) associated with the customer, this is then in turn associated with transaction account information which may be entered by the customer, for example by way of a magnetic strip credit card being swiped by the customer across a card reader (16). The invention permits a transaction and subsequent transactions associated with a customer via the identifier to be charged to an account associated with the customer identifier and can permit the customer to alter the account details associated with the customer identifier.



**FIG. 1**

## Description

**[0001]** The present invention relates to a method of, and apparatus for, retail transaction processing, and is particularly applicable to transactions at a retail transaction station such as a fuel dispenser.

**[0002]** Retail transaction stations, such as, the CRIND® (Card Reader in Dispenser) system for fuel dispensers manufactured and sold by Marconi Commerce Systems, the assignee of the present invention, have long included the ability for customers to pay for their purchase directly at the station using a credit or debit card. This is usually accomplished by providing a card reader in the station to read transaction account information from the magnetic stripe of the customer's credit card. In most cases, the customer can use one of several accepted credit or debit cards.

**[0003]** A more modern development in retail transaction station technology is the automatic recognition of customers, such as through the use of a Radio Frequency Identification (RFID) transponder. An example of such a system is the TRIND™ (Transponder Reader in Dispenser) system for fuel dispensers manufactured and sold by Marconi Commerce Systems. Each RFID transponder communicates an identification code when interrogated by an RFID interrogator located at the retail transaction station. This identification code is associated with a particular customer. A controller associated with the station accesses a database that associates the identification code or other customer identifier with a particular transaction account to which the customer has previously authorized access.

**[0004]** The automatic customer recognition and payment is typically set up when the customer purchases or is issued an RFID transponder, or "tag." The customer activates the transponder by supplying transaction account information, such as a credit card or debit card account number, expiration date, and the like. Typically the customer either calls a toll-free telephone number and provides this information to a customer service representative, or enters the information on a form and mails or faxes the form to an account center. Once approved and activated, the customer simply brings the RFID transponder, which may be located on or in his or her vehicle, on a key chain, in a card in his or her wallet, etc., into the operative range of the interrogator at the retail transaction station. The customer is recognized, and purchases made at the retail transaction station are automatically charged to the previously supplied transaction account. An example of such a system is described in PCT Patent WO 97/24689 by Dresser Industries, Inc., Mobil Oil Corp., and Texas Instruments, Inc. entitled "Dispensing System and Method with Radio Frequency Customer Identification."

**[0005]** According to a first aspect of the present invention there is provided a method of associating a customer transaction account with a customer identifier for processing transactions at a retail transaction station,

the method comprising the steps of: a) identifying the customer; b) obtaining transaction account information from the customer at said retail transaction station; and c) associating said transaction account information with the customer.

**[0006]** Preferably step a) comprises detecting an identifier associated with the customer and step b) comprises obtaining transaction account information from a customer input wherein the customer identifier need not be exclusively associated with the transaction account input by the customer.

**[0007]** The step of identifying the customer can comprise reading a customer identifier at said retail transaction station by means of an RFID reader, optical reader, card reader, biometric reader or camera with an associated image recognition system.

**[0008]** Preferably the customer is identified by interrogating a transponder associated with the customer which may be mounted on a customer's vehicle.

**[0009]** The step of obtaining transaction account information preferably comprises reading transaction account information using a magnetic stripe card reader at said retail transaction station. This enables the customer to swipe a credit or similar card he wishes to be associated with his identifier through a card reader with subsequent transaction being charged to that account until the customer modifies the account details.

**[0010]** According to a second aspect of the invention there is provided a retail transaction station that communicates wirelessly to a wireless communication device, the transaction station comprising: a controller; an interrogator communicatively coupled to said controller; and a transaction account reader communicatively coupled to said controller for reading transaction account information; wherein said controller causes said interrogator to communicate with the wireless communication device to obtain a customer identifier and associate said customer identifier with said transaction account information ascertained from said transaction account reader.

**[0011]** According to a third aspect of the present invention there is provided a system for conducting financial transactions with a customer, the system being arranged to modify a transaction account identifier associated with the customer and comprising: a) a retail transaction station having a customer identification unit and a card reader; b) a database adapted to include a plurality of transaction account identifiers, with each transaction account identifier being associated with a customer; c) a processing station communicatively connected to said retail transaction station and operative to receive a customer identifier and a transaction account identifier from said retail transaction station, and to modify the transaction account identifier associated with a customer in the database.

**[0012]** The present invention enables a customer at a retail transaction station to input information identifying a transaction account directly at the retail transaction

station. The transaction account information is uniquely associated with the customer by way of the customer identifier and this association is preserved in a database. The database is controlled by a processing station, which may be contained within the retail transaction station or may be located remotely from and communicatively connected to the retail transaction station. The processing station is further connected to a network for performing financial transaction processing with the customer's transaction account to effect payment for goods and/or services that the customer purchases at the retail transaction station.

**[0013]** As used herein, the term "transaction account" is to be construed broadly. It refers to any financial account that a customer may use to pay for purchases at a retail transaction station, for example, a credit card or debit card account. Similarly, as used herein, the term "transaction account information" is to be construed broadly to encompass any information necessary to identify, access, debit, transfer from, or charge to the transaction account. The most common transaction account information comprises a credit or debit card account number, but additionally or alternatively may comprise an electronic funds routing number, purchase order number, or similar information. In general, a "transaction account" is a source of credit or funds to pay for a customer's purchase, and "transaction account information" is the account number, access code, or any other information necessary to access the transaction account.

**[0014]** As used herein, to "access" a transaction account is to perform such steps as are necessary to locate the account, verify or validate that the customer is authorized to debit or charge to the account, and effect payment for the customer's goods and/or services from the transaction account. In particular applications, a system may initially access a transaction account to obtain authorization for a pending purchase, such as the dispensing of fuel from a fuel dispenser, and subsequently access the transaction account to charge a known total. In other applications, a system may access a transaction account only once, to charge a known total amount. A transaction account may be accessed across a wide area computer network, with communications links comprising wired and wireless telephone lines, satellite communications, terrestrial radio links, and the like. Transaction account processing is well known in the art, and the specifics of accessing an account are not further elucidated herein.

**[0015]** Several embodiments of the present invention will now be described by way of example only with reference to the accompanying figures, of which:

Figure 1 is a perspective view of a retail transaction station;

Figure 2 illustrates various types of transponders;

Figure 3 is a functional block diagram of an interrogator and transponder;

Figure 4 is a block diagram of a system for processing transactions initiated at a single retail transaction station;

Figure 5 is a flow chart depicting the process of updating a customer's transaction account information;

Figure 6 is a block diagram of a system for processing transactions having a plurality of retail transaction stations controlled by a site controller;

Figure 7 is a perspective view of a fuel dispenser;

Figure 8 depicts a plurality of fuel dispensers and a site controller at a service station; and

Figure 9 is a flow chart depicting the process of updating a customer's transaction account information and performing retail transactions at a fuel dispenser.

**[0016]** A description of one embodiment of the present invention is made with reference to Figure 1, depicting a retail transaction station, indicated generally by the numeral 10. A retail transaction station 10 is a system equipped and operative for interaction with customers to facilitate the purchase of goods and/or services. For example, goods purchased may comprise information, data, or entertainment in electronic form. Examples include news reports, weather forecasts, and music, video, or other content in electronic format, that the customer may order and purchase at the retail transaction station, and that may additionally be downloaded directly into the customer's automotive computer, handheld computing device, musical playback device, or the like. Services may include a car wash purchase, placing a telephone call, ordering a movie rental, etc. Another example of a retail transaction station 10 may include a vending machine. One such device is described in PCT Patent Application WO 96/06415, "Method and Apparatus for Vending Goods in Conjunction with a Credit Card Accepting Fuel Dispensing Pump," the disclosure of which is incorporated herein in its entirety. In general, any type of goods and/or services may be ordered and purchased through a retail transaction station 10; the above examples are illustrative only, and should not be construed as limiting the present invention.

**[0017]** The retail transaction station 10 contains at least one input device which may be any device functional to establish customer communication with the retail transaction station 10 for the selection of desired goods and/or services and may of a form that requires no physical contact, such as a transponder or other wireless communication, a smart card, speech recognition, or a direct link to a secondary device such as a PDA or laptop computer. In the embodiment depicted in Figure 1, the retail transaction station 10 contains a keypad 12 disposed in housing 13, and soft function keys 14 disposed along display 18 as input devices.

**[0018]** Retail transaction station 10 may also contain a payment device for allowing the customer to pay for

his purchases. This may be done directly, for example with a cash acceptor. Alternatively, the payment device may be effective to read transaction account information, for example, a magnetic stripe card reader. Alternatively, or additionally, a payment device may comprise an interrogator effective to read payment information wirelessly from a customer transponder. The payment device may alternatively comprise an optical reader effective to detect and interpretive visual indicia, such as a bar code. Additionally or alternatively, the payment device may be effective to recognize the consumer, either to thereby associate previously stored transaction account information with the consumer, or as a security measure to validate transaction account information otherwise received. This may comprise, for example, a camera and associated facial recognition system or a biometric sensor, for example, a camera effective to detect and interpretive eye iris patterns, a fingerprint detector, or the like.

**[0019]** In the embodiment depicted in Figure 1, the retail transaction station 10 contains an interrogator 16 disposed in housing 13 for identifying customers via a transponder in the customer's possession, as is more fully explained below. Retail transaction station 10 additionally contains a magnetic stripe card reader 17 disposed in housing 13 that is operative to read transaction account information from a customer's credit card. The card reader 17 may serve as a payment device for new customers or those not recognized by interrogator 16. Additionally, card reader 17 functions as an input device, to receive transaction account information from a recognized customer to update or alter the transaction account associated with his customer identifier. However, the present invention is not limited to a magnetic stripe card reader for these functions. Transaction account information may additionally or alternatively be read by a bar code reader, for example, or other account information reader, as known in the art.

**[0020]** The retail transaction station 10 additionally includes an output to facilitate communication with the customer. The output may present the customer with instructions, and various menus or other selections of goods and/or services available for purchase. The output may be audible. Additionally, the output may provide for the actual delivery of goods in electronic form. This may be accomplished through communication to a secondary device, such as a computer in the consumer's automobile, a PDA or laptop computer, a mobile telephone terminal, a musical playback device, or the like.

**[0021]** In the embodiment depicted in Figure 1, the retail transaction station 10 contains an output display 18 disposed in housing 13. Soft function keys 14, disposed along the sides of display 18, may be programmed to cooperate with a menu presented on display 18 to facilitate interaction with the customer.

**[0022]** Interrogator 16, contained in retail transaction station 10, may be a Radio-Frequency Identification

(RFID) interrogator. As used herein, the term "interrogator" refers to a wireless communications device capable of establishing communications with a plurality of corresponding wireless communication devices, herein referred to as "transponders," for the purpose of discriminating among and identifying individual transponders, e.g., by receiving and decoding an identification code. Wireless interrogators are also referred to in the art as "readers." Interrogator 16 is operative to detect and read an identification code from transponders, also commonly referred to in the art as "tags," within its range. The range of interrogator 16 is designed and configured so as to encompass the area in the immediate vicinity of retail transaction station 10, but no further. Specifically, the range of interrogator 16 should be extensive enough to detect the transponders carried by customers who wish to access the retail transactions station 10 to purchase goods and/or services.

**[0023]** Each transponder is programmed with a unique identification code that it transmits to interrogator 16 whenever it comes within range. A transponder is issued to or purchased by a customer, and the customer carries the transponder, or alternatively, may have the transponder mounted to his or her vehicle. As used herein, a transponder "in the customer's possession" means a transponder physically proximate to the customer, whether carried by or on the customer or attached to or mounted on or in the customer's vehicle. When the customer approaches the retail transactions station 10, his or her transponder communicates its unique identification code to the interrogator 16, thus uniquely identifying the individual customer.

**[0024]** Illustrative examples of transponder placement are shown in Figure 2. In Figure 2A, transponder 20 is installed in customer vehicle 22. In Figure 2B, transponder 20 is embedded in card 24, of the general size and shape of a conventional credit card. In Figure 2C, transponder 20 is embedded in key chain fob 26.

**[0025]** In operation in one embodiment of the present invention, interrogator 16 outputs a single frequency RF signal, with each passive transponder 20 responding by communicating a unique identification code via a responsive signal.

**[0026]** Figure 3 depicts a functional block diagram of an interrogator 16 and a representative transponder 20. One of ordinary skill in the art will understand that there are many other different types of wireless communication devices that allow electronic communication, and the present invention is not limited to any one particular type. The transponder 20 comprises control system 30, wireless communication electronics 32, antenna 34, and memory 38. The control system 30 is connected to memory 38 for retrieving an identification code.

**[0027]** The interrogator 16 contains interrogation communication electronics 40 and an interrogation antenna 42. The interrogator 16 communicates to the transponder 20 by emitting an electronic signal.

**[0028]** When the transponder antenna 34 is in the

presence of the field 46 emitted by the interrogator antenna 42, the wireless communication electronics 32 are energized thereby energizing the transponder 20. The wireless communication electronics 32 receive the signal 44 and divides down the frequency, generating a synchronous clock that is sent to control system 30 to synchronize its actions. The control system 30 accesses its identification code from memory 38, and encodes the data according to any of several data encoding algorithms as are well known in the art (e.g., Non-Return to Zero (NRZ), Differential Biphase, Manchester Biphase, etc.). The encoded data is serially clocked to wireless communication electronics 32. Wireless communication electronics 32 modulates the data according to any several data modulation algorithms as are well known in the art (e.g., Direct, Frequency Shift Keying, Phase Shift Keying, etc.). Wireless communication electronics 32 then shunts antenna 34, generating backscatter modulation of the field 46 emitted by interrogator antenna 42. Interrogation communications electronics 40 detects the backscatter modulation at interrogator antenna 42 (or alternatively, via another antenna), and demodulates and decodes the received signal to recover the identification code transmitted by transponder 20.

**[0029]** Referring to Figure 4, the retail transaction station 10 is communicatively connected a controller 50, also referred to herein as a processing station. Controller 50 may be contained within the housing 13 of the retail transaction station 10, or it may be located remotely, as depicted in Figure 4. Controller 50 is operative to access and control a database 52 that contains customer identifiers and associated transaction account information. The customer identifiers correspond to the identification codes transmitted by each customer's transponder 20 to the interrogator 16 at the retail transaction station 10, and serve to uniquely identify each customer. Alternatively, the transponder 20 identification code could be used to index or generate a separate customer identifier, which could for example be a customer's social security number or driver's license number, or alternatively could be a random or pseudo-random number generated from the transponder identification code. The essential characteristic of a customer identifier is that it uniquely identifies each individual customer. Associated with each customer identifier in the database 52 is information regarding one or more transaction accounts to which the customer may charge the purchase of goods and/or services made at the retail transaction station 10. The transaction account information may be input to the controller 50 for inclusion in the database 52 manually, e.g., by a customer service representative following directions from a mail-in form or from a customer calling a customer service number.

**[0030]** Alternatively, according to the present invention, the customer may enter or update the transaction account information associated with his customer identifier in the database 52 by inputting the transaction account information directly at the retail transaction station

10. This process is described in flowchart format in figure 5. First, upon the customer's arrival at the retail transaction station 10, interrogator 16 communicates with the customer's transponder 20, thus obtaining a unique code that identifies the customer (step 60). If no corresponding customer identifier is found in database 52, e.g., if the customer has just purchased or been issued a transponder 20, or if no transaction account is associated with the customer identifier, e.g., the customer has not yet submitted information regarding a valid transaction account, the customer is prompted to enter transaction account information, e.g., by swiping a valid credit card through card reader 17. Additionally, if the customer identifier and associated valid transaction account are found in database 52, the customer may optionally be presented with a prompt or menu option inviting him or her to update his or her transaction account (step 62). In either case, the customer enters new transaction account information, e.g., by swiping a credit card through card reader 17, at the retail transaction station (step 64). The transaction account information may, of course, be entered otherwise. The customer may, for example, enter an account number on the keypad 12, or may navigate through a series of menu options utilizing soft function keys 14 in conjunction with display 18 to select from among a plurality of known transaction accounts, or by a variety of other means. Once the customer has been identified and has entered new transaction account information, the customer identifier and the transaction account information are communicated to the controller 50. Controller 50 associates the customer identifier with the transaction account information, and stores the association in the database 52 (step 66). Note that more than one transaction account may be associated with each customer identifier, with the customer selecting from among known transaction accounts, or alternatively entering information regarding a new transaction account, prior to charging the customer's purchase. When the transaction account information has been updated in database 52, the controller 50 may access the associated transaction account to process the customer's purchase of goods and/or services (step 68). This may be accomplished across a wide area network, establishing communication with a variety of financial institutions 54. The specifics of electronic transaction account processing are well known in the art, and are not further explicated herein.

**[0031]** Figure 6 depicts another embodiment, wherein a plurality of retail transaction stations 10 are controlled by a site controller 56. This configuration is common, for example, at a service station, wherein the retail transaction stations 10 comprise fuel dispensers, and the site controller 56 it is located in an associated kiosk, convenience store, or the like. In this embodiment, the site controller 56 collects customer identifiers and transaction account information from each remote transaction station 10, and forwards the information to controller 50, that is typically located remotely from the site controller

56. Transaction processing by controller 50 proceeds as described above.

**[0032]** The retail transaction station 10 may be in the form of a fuel dispenser 70, as depicted in Figure 7 incorporating the same features as on the unit 10 of Figure 1, but including additional features common to fuel dispensers.

**[0033]** Figure 8 depicts a typical service station, indicated generally as 92. Each fuel dispenser 70 is communicatively connected to a site controller 56, located within an appurtenant convenience store 94. In this configuration, each fuel dispenser 70 may contain an interrogator 90 effective to detect and communicate with the customer transponders that come within its range. The transmitting antenna of the interrogator 90 is positioned and calibrated so as to limit the range of the interrogator 90 to an area immediately adjacent to the respective side of the fuel dispenser 70, i.e., the area of pavement directly adjacent to the fuel dispenser 70 that will be occupied by a customer's vehicle during fueling. Site controller 56 is communicatively coupled to a controller 50 containing customer identifier and transaction account information in a database 52, as depicted in Figure 6.

**[0034]** Referring to Figure 9, when a customer drives up to a particular fuel dispenser 70, and hence within the operative field of the associated interrogator 90, the customer's transponder in the energized and transmits its identification code. This identification code is received at the interrogator 90 (step 100), and is passed to the site controller 56 and thence on to the controller 50. Controller 50 indexes database 52 with the customer identifier to ascertain whether the customer is known to the system (i.e., the customer identifier is in the database 52), and if so, if there is a valid transaction account associated with that customer identifier (step 102). If the customer is both known and has a valid transaction account in database 52, the customer may be prompted at the fuel dispenser 70 to indicate whether he or she wishes to update the system to access a different transaction account (step 104). If the customer response affirmatively, or alternatively if either the customer identifier or an associated valid transaction account was not found in database 52, then the customer is prompted to enter information regarding a transaction account (step 106). The customer may enter new transaction account information in several ways, e.g., by swiping a credit card through a card reader at the fuel dispenser 70. The fuel dispenser 70 may additionally require the customer to enter authorization information, such as a Personal Identification Number (PIN) that may be necessary to authorize the customer's access to the transaction account. The new transaction account information is then forwarded by the site controller 56 to controller 50. Controller 50 verifies, via access across the network to financial institutions 54 (see Figure 6) that the new transaction account exists, is valid, and that the customer is authorized to access it (step 108). The controller 50 may also at this point pre-authorize a fuel purchase transac-

tion in an amount estimated to approximate the customer's fuel purchase.

**[0035]** If the transaction account does not exist, is inactive, or the customer is not authorized to access it, the fuel dispenser 70 prompts the customer to enter information regarding a different transaction account (step 106). If the transaction account is valid and accessible, the controller 50 associates the customer identifier with the transaction account information, and stores the association in the database 52 (step 110). At this point, the customer has been identified, and has a valid transaction account associated with him or her. This is also the case when a customer is recognized and elects not to update his or her transaction account information at step 104 and the fuel dispenser 70 is enabled.

**[0036]** When the desired amount of fuel has been dispensed into the customer's vehicle and the pump has been disengaged at the fuel dispenser 70, the fuel purchase total, along with any other purchases made by the customer at the fuel dispenser 70, are forwarded by the site controller 54 to controller 50 for processing via the transaction account (step 114). It will be recognized that the process described above and depicted in Figure 9 is illustrative only, and the present invention is not limited thereby. The procedural steps described may be performed in a different order, some steps may be omitted, and additional steps may be included. Additionally, some of the steps described could be performed in a matter other than that explicated herein.

**[0037]** Although the present invention has been described herein with respect to particular features, aspects and embodiments thereof, it will be apparent that numerous variations, modifications, and other embodiments are possible within the scope of the present invention as claimed.

## Claims

1. A method of associating a customer transaction account with a customer identifier for processing transactions at a retail transaction station, **characterised in that** the method comprises the steps of:
  - a. identifying the customer;
  - b. obtaining transaction account information from the customer at said retail transaction station; and
  - c. associating said transaction account information with the customer.
2. The method of claim 1 wherein step a) comprises detecting an identifier associated with the customer and step b) comprises obtaining transaction account information from a customer input **characterised in that** the customer identifier need not be exclusively associated with the transaction account input by the customer.

3. The method of claim 1 or 2 wherein said step of identifying the customer comprises reading a customer identifier at said retail transaction station by means of an RFID reader, optical reader, card reader, biometric reader or camera with an associated image recognition system. 5
4. The method of claim 1, 2 or 3 wherein said step of identifying the customer is performed by interrogating a transponder associated with the customer. 10
5. The method of claim 4 wherein said transponder is mounted on a customer's vehicle.
6. The method of any preceding claim wherein said step of obtaining transaction account information comprises reading transaction account information using a magnetic stripe card reader at said retail transaction station. 15
7. The method of any preceding claim further comprising the step of validating said transaction account information before associating said transaction account information with the customer. 20
8. The method of claim 7, wherein said step of validating said transaction account information comprises the step of obtaining a PIN from the customer to determine if the customer is authorized to use said transaction account. 25
9. The method of claim 7 or 8, wherein the step of validating said transaction account information further comprises the step of communicating said transaction account information to a network to determine if the transaction account information is valid. 30
10. The method of any preceding claim further comprising the step of charging any purchases made by the customer at said retail transaction station to said transactional account currently associated with said customer identifier. 35
11. The method of any preceding claim further including the step of querying with the customer whether to update the transaction account information associated with the customer. 40
12. The method of any preceding claim further comprising performing a fuel dispensing transaction and charging the transaction to the account associated with the customer. 45
13. The method of claim 12 wherein said transaction account information and said customer identifier are associated at a site controller remote from said fuel dispenser. 50
14. The method of claim 10, 12 or 13 wherein charging purchases to said transaction account comprises accessing said transaction account on a network remote from said fuel dispenser.
15. A retail transaction station that communicates wirelessly to a wireless communication device, the transaction station comprising:
- a controller;
  - an interrogator communicatively coupled to said controller; and
  - a transaction account reader communicatively coupled to said controller for reading transaction account information;
- characterised in that** said controller causes said interrogator to communicate with the wireless communication device to obtain a customer identifier and associate said customer identifier with said transaction account information ascertained from said transaction account reader.
16. The retail transaction station of claim 15 further comprising a database to store said customer identifiers and said associated transaction account information.
17. A system for conducting financial transactions with a customer, the system being **characterised in that** it is arranged to modify a transaction account identifier associated with the customer and comprising:
- a. a retail transaction station having a customer identification unit and a card reader;
  - b. a database adapted to include a plurality of transaction account identifiers, with each transaction account identifier being associated with a customer;
  - c. a processing station communicatively connected to said retail transaction station and operative to receive a customer identifier and a transaction account identifier from said retail transaction station, and to modify the transaction account identifier associated with a customer in the database.
18. The system of claim 17 wherein said processing station is operative to enter a new transaction account identifier into said database and to associate said new transaction account identifier with a customer.
19. The system of claim 17 or 18 wherein said processing station is a controller within said retail transaction station. 55

20. The system of claim 17 or 18 wherein said processing station is a site controller remote from said retail transaction station.

21. The system of any one of claims 17 to 20 wherein said processing station is operative to modify the transaction account identifier associated with a customer by adding one or more additional transaction account identifiers and associating them with the same customer, or by substituting a new transaction account identifier for a pre-existing transaction account identifier and associating the new transaction account identifier with the same customer.

22. The system of any one of claims 17 to 21 wherein said customer identification unit is selected from the group consisting of an RFID reader, optical reader, card reader, biometric reader, and camera with an associated image recognition system.

23. The system of claim 22 wherein said customer identification unit is an RFID reader operative to obtain said customer identifier by reading a code from an RFID transponder associated with the customer.

24. The system of claim 23 wherein said transponder is mounted to a customer's vehicle.

5

10

15

20

25

30

35

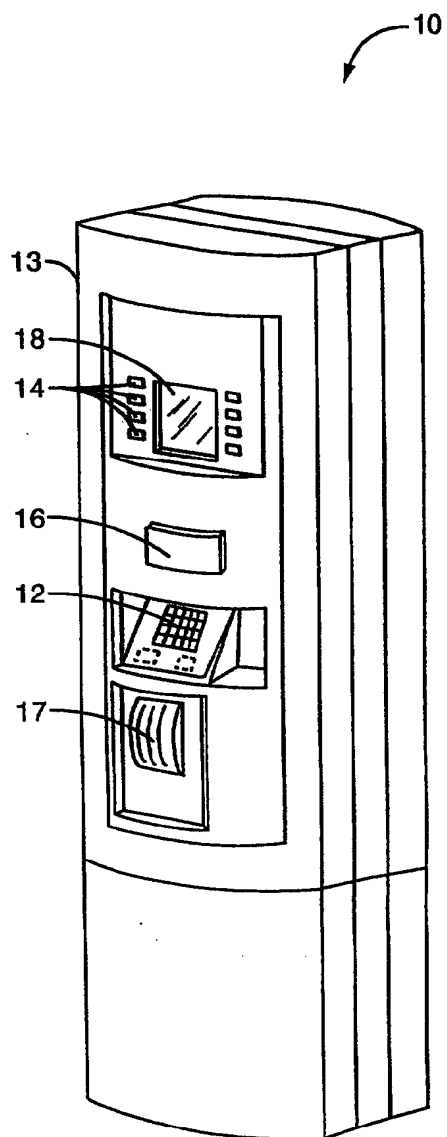
40

45

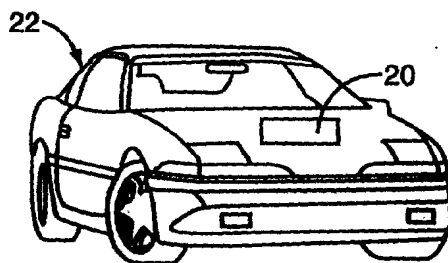
50

55

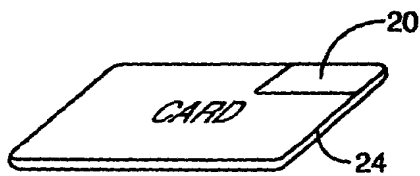




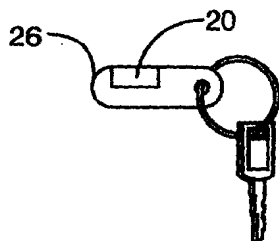
**FIG. 1**



**FIG. 2A**



**FIG. 2B**



**FIG. 2C**

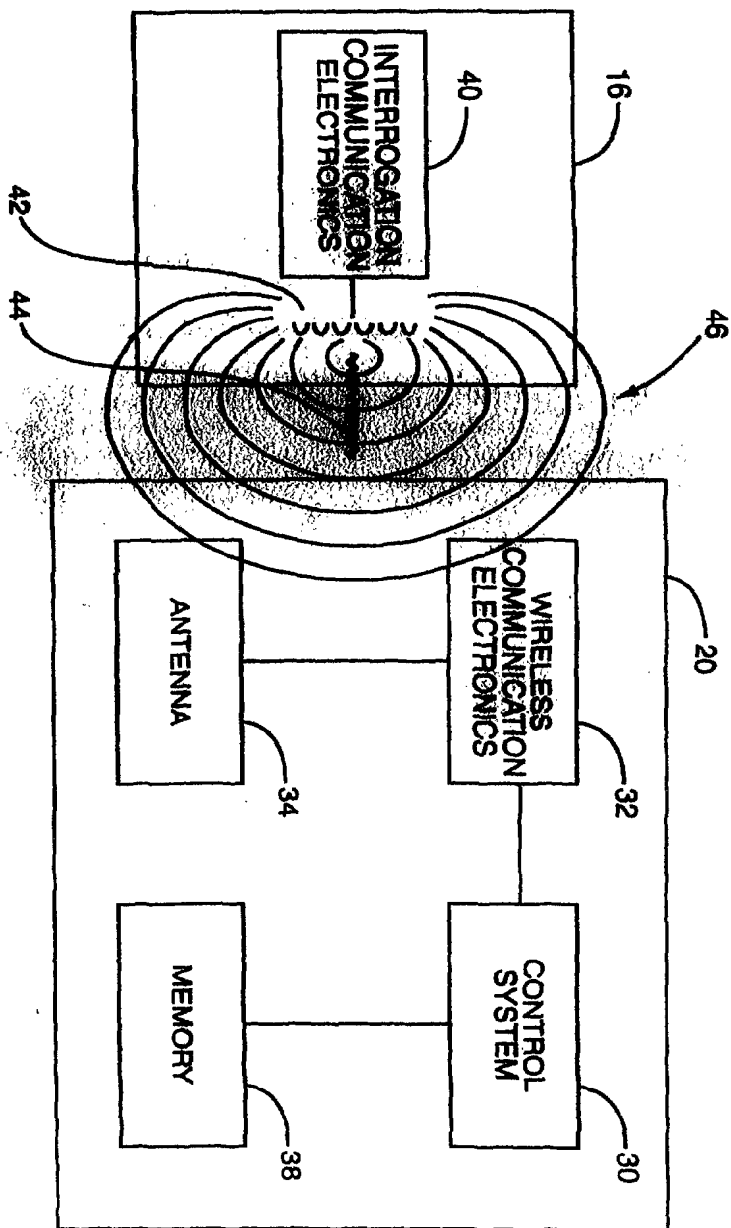


FIG. 3

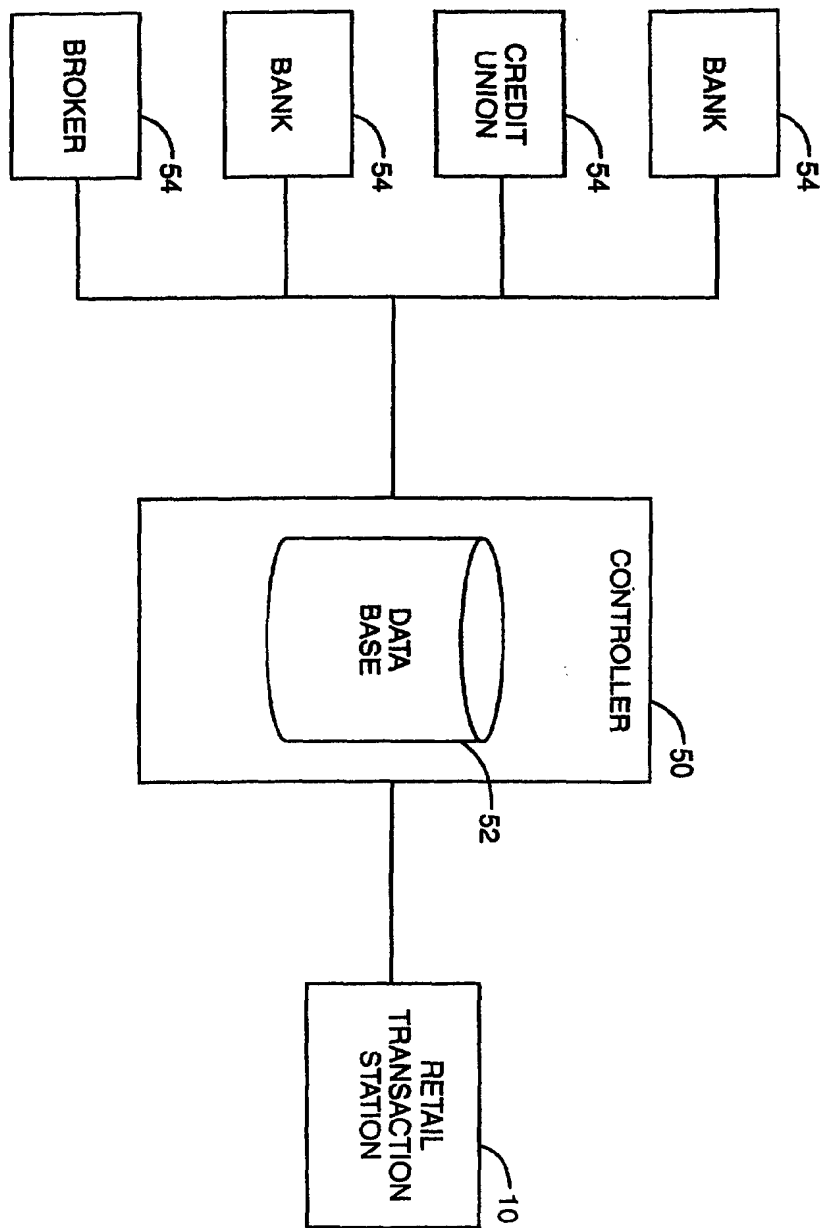
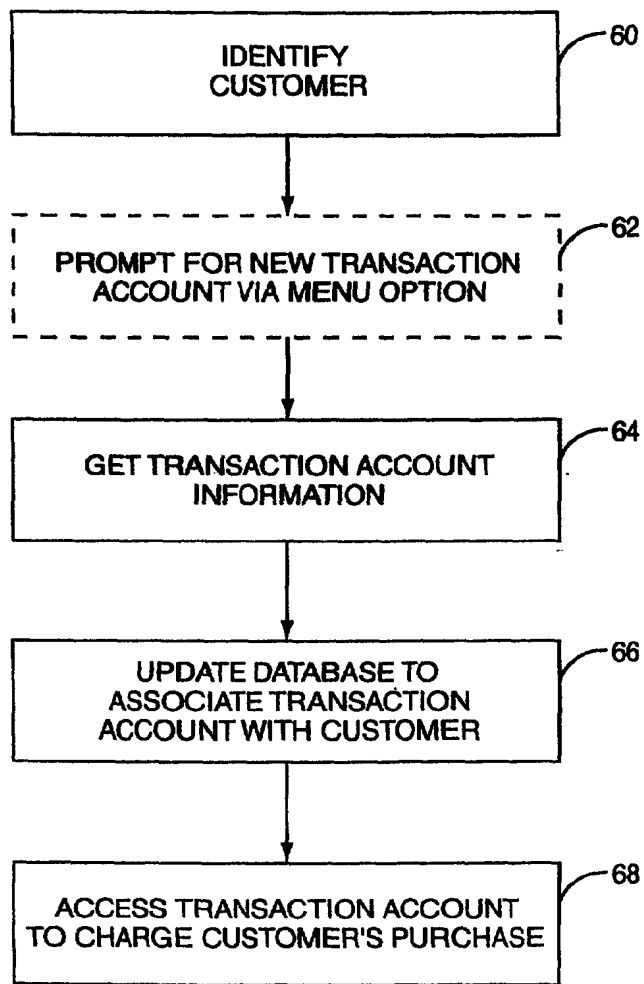


FIG. 4



**FIG. 5**

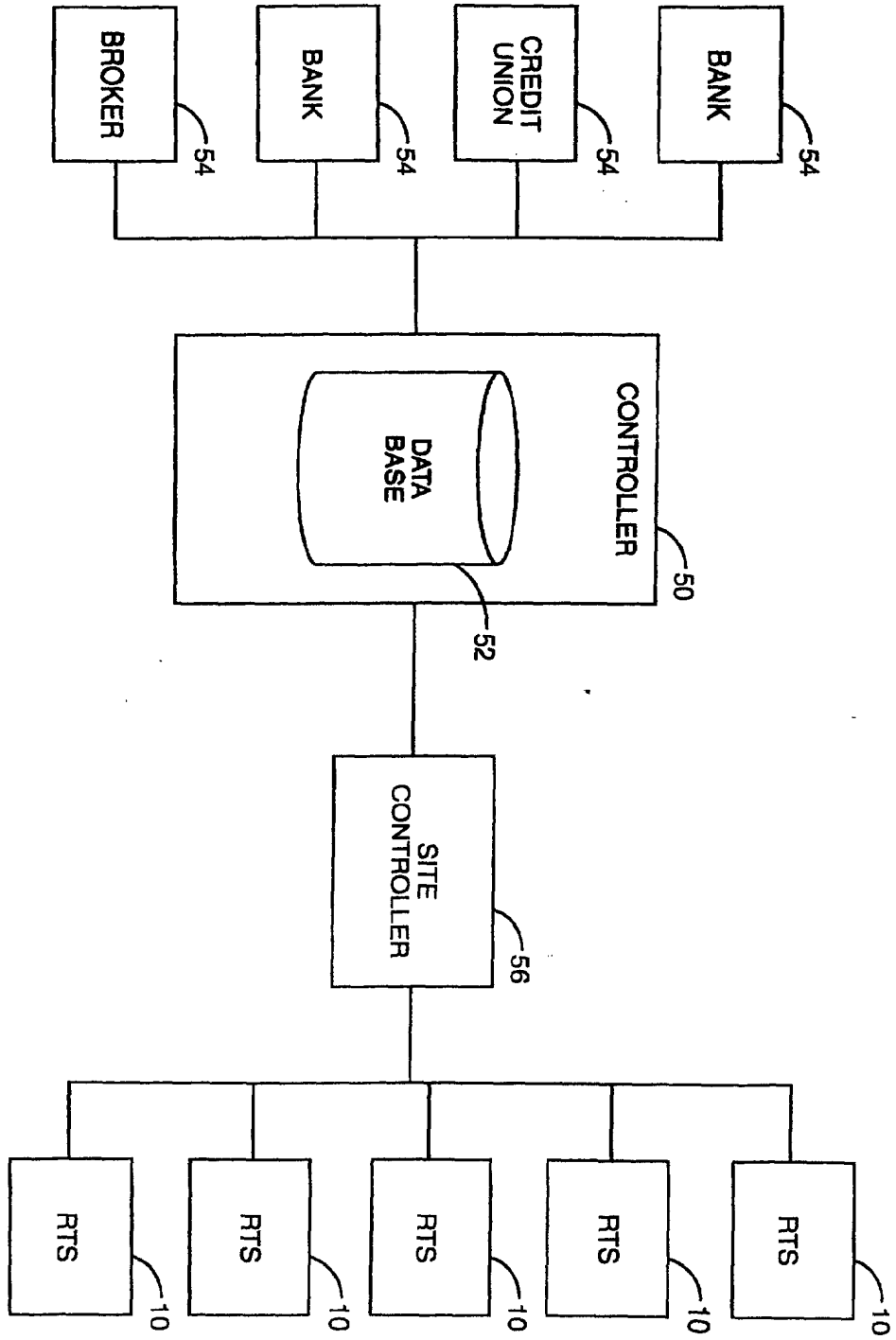


FIG. 6

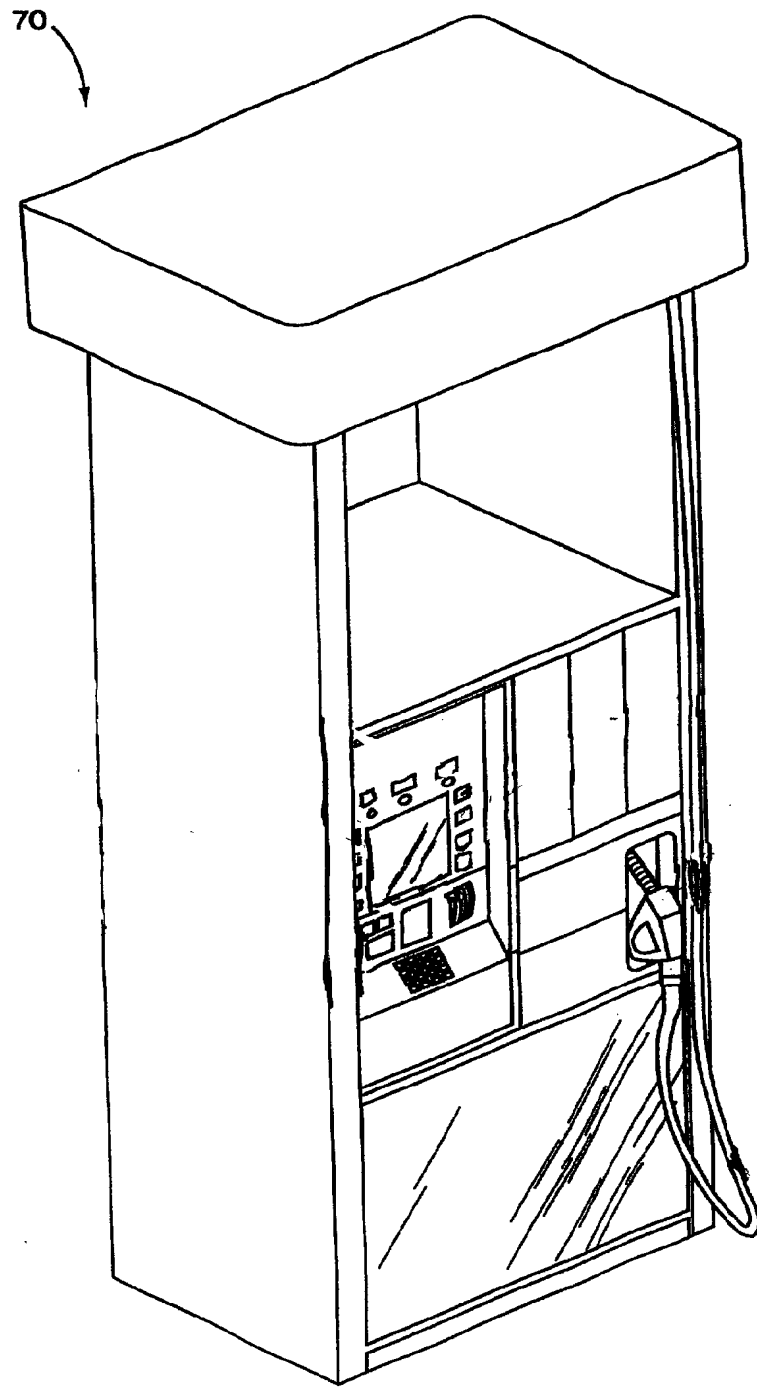


FIG. 7

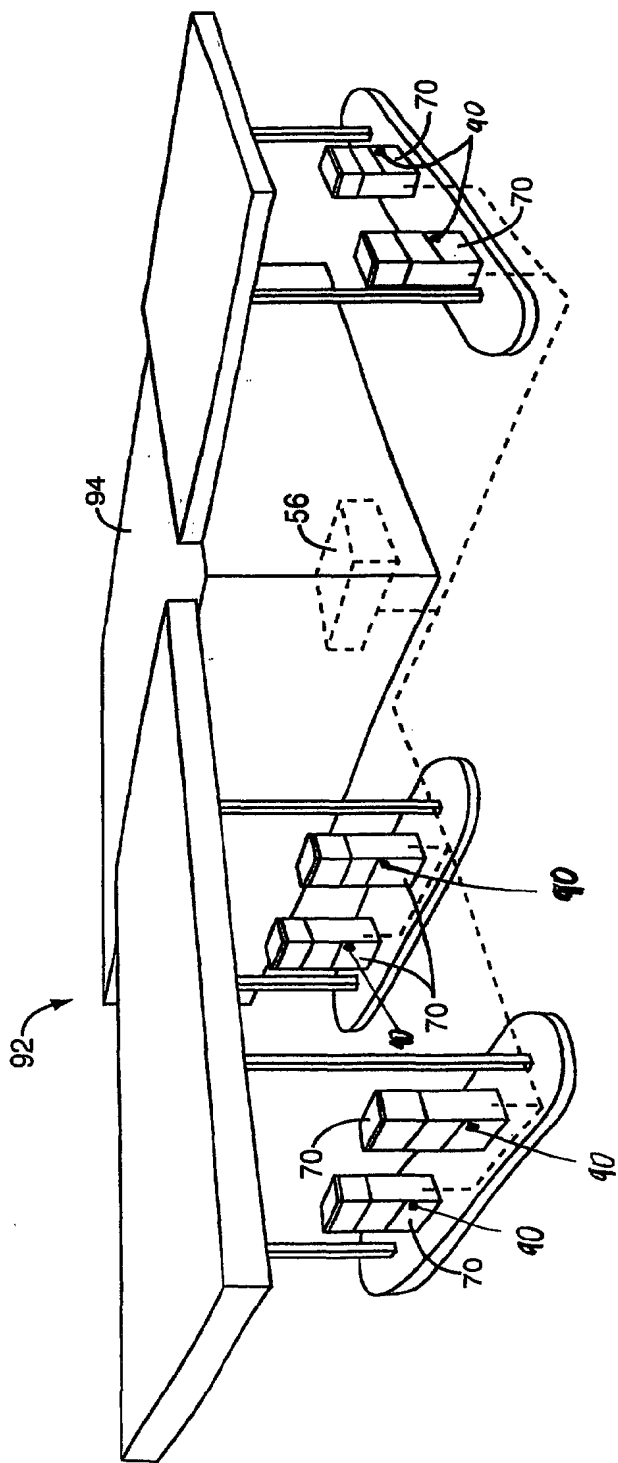


FIG. 8



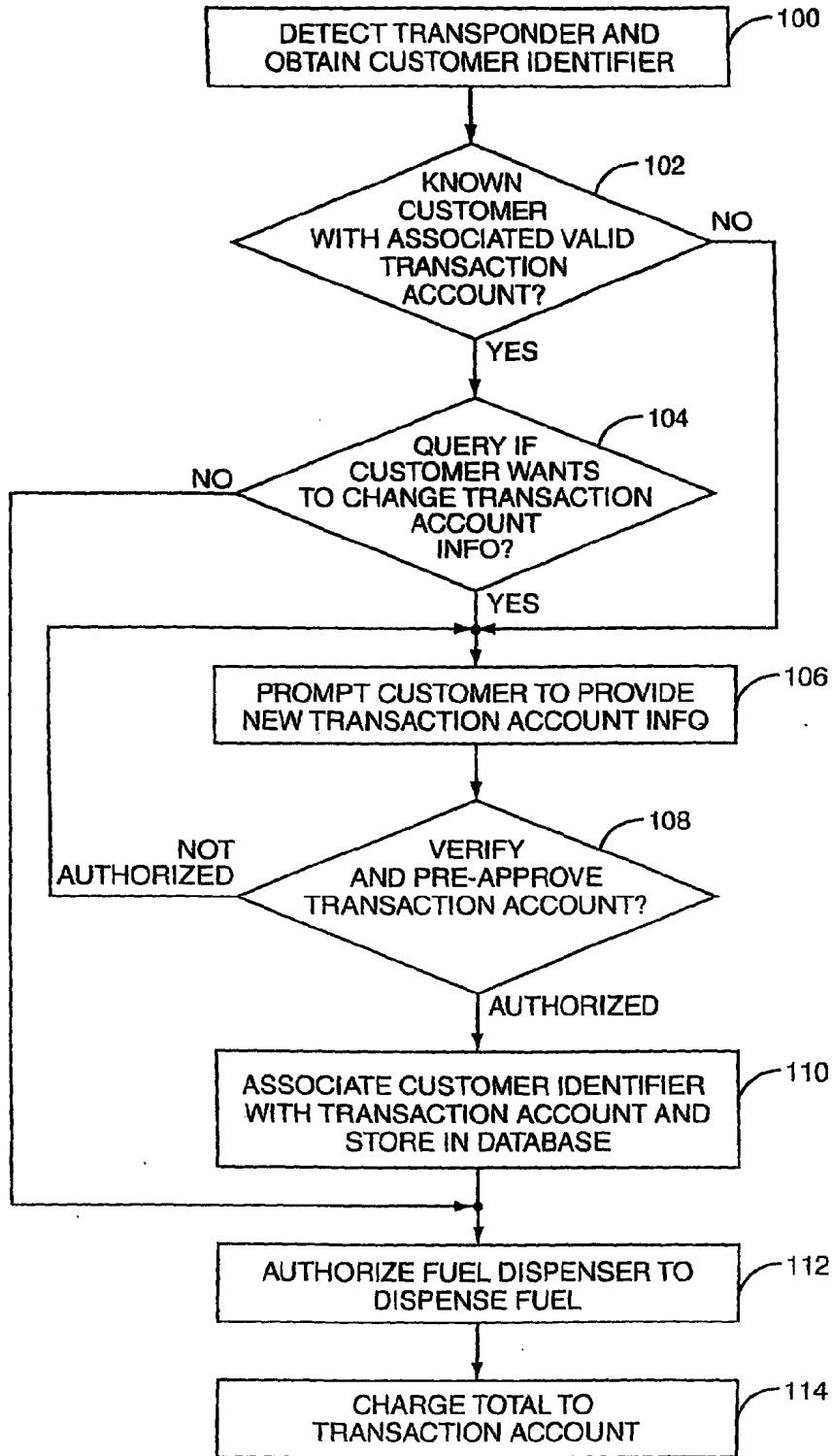


FIG. 9